



INVERTER

Plug-in option

FR-A8AP E KIT

INSTRUCTION MANUAL

Encoder feedback control

Vector control

PRE-OPERATION INSTRUCTIONS	1
INSTALLATION	2
ENCODER SPECIFICATIONS	3
ENCODER FEEDBACK CONTROL	4
VECTOR CONTROL	5

Safety instructions

Thank you for choosing this Mitsubishi Electric inverter plug-in option.

This Instruction Manual provides handling information and precautions for use of this product. Incorrect handling might cause an unexpected fault. Before using this product, read all relevant instruction manuals carefully to ensure proper use.

Please forward this Instruction Manual to the end user.

Do not attempt to install, operate, maintain or inspect this product until you have read this Instruction Manual and supplementary documents carefully. Do not use this product until you have a full knowledge of this product mechanism, safety information and instructions. In this Instruction Manual, the safety instruction levels are classified into "WARNING" and "CAUTION".

 **WARNING** Incorrect handling may cause hazardous conditions, resulting in death or severe injury.

 **CAUTION** Incorrect handling may cause hazardous conditions, resulting in medium or slight injury, or may cause only material damage.

Note that even the  **CAUTION** level may lead to a serious consequence depending on conditions. Be sure to follow the instructions of both levels as they are critical to personnel safety.

◆ Electric Shock Prevention

WARNING

- Do not remove the front cover or the wiring cover while the power of the inverter is ON, and do not run the inverter with the front cover or the wiring cover removed, as the exposed high voltage terminals or the charging part of the circuitry can be touched. Doing so may cause an electric shock.
 - Even if power is OFF, do not remove the front cover of the inverter except for wiring or periodic inspection, as the inside of the inverter is charged. Doing so may cause an electric shock.
 - Before wiring or inspection, check that the LED display of the operation panel is OFF. Any person who is involved in wiring or inspection shall wait for at least 10 minutes after the power supply has been switched OFF and check that there is no residual voltage using a tester or the like. For some time after the power-OFF, a high voltage remains in the smoothing capacitor, and it is dangerous.
 - Any person who is involved in wiring or inspection of this product shall be fully competent to do the work.
 - The plug-in option must be installed before wiring. Otherwise you may get an electric shock or be injured.
 - Do not touch the plug-in option or handle the cables with wet hands. Doing so may cause an electric shock.
 - Do not subject the cables to scratches, excessive stress, heavy loads or pinching. Doing so may cause an electric shock.
-

◆ Injury Prevention

CAUTION

- The voltage applied to each terminal must be as specified in the Instruction Manual. Otherwise an explosion or damage may occur.
 - The cables must be connected to the correct terminals. Otherwise an explosion or damage may occur.
 - The polarity (+ and -) must be correct. Otherwise an explosion or damage may occur.
 - While power is ON or for some time after power OFF, do not touch the inverter as it will be extremely hot. Doing so may cause burns.
-

◆ Additional Instructions

The following instructions must be also followed. If the product is handled incorrectly, it may cause unexpected fault, an injury, or an electric shock.

CAUTION

Transportation and installation

- Do not install or operate the plug-in option if it is damaged or has parts missing.
- Do not stand or rest heavy objects on the product.
- Ensure the mounting orientation of this product is correct.
- Foreign conductive objects must be prevented from entering the inverter. That includes screws and metal fragments or other flammable substance such as oil.
- If halogens (including fluorine, chlorine, bromine, and iodine) contained in fumigants for wood packages enter this product, the product may be damaged. Prevent the entry of fumigant residuals or use an alternative method such as heat disinfection. Note that sterilization or disinfection of wood packages should be performed before packing the product.

Trial run

- Before starting operation, confirm or adjust the parameter settings. Failure to do so may cause some machines to make unexpected motions.
-

WARNING

Usage

- Do not modify the equipment.
 - Do not remove any part which is not instructed in this manual. Doing so may lead to fault or damage of the product.
-

CAUTION

Usage

- As all parameters return to their initial values after Parameter clear or All parameter clear is performed, the parameters must be set again as required before the operation is started.
- Static electricity in your body must be discharged before you touch the product.

Maintenance, inspection and parts replacement

- Do not carry out a megger (insulation resistance) test.

Disposal

- The inverter must be treated as industrial waste.
-
-

General instruction

- For clarity, illustrations in this Instruction Manual may be drawn with covers or safety guards removed. Ensure all covers and safety guards are properly installed prior to starting operation.
-



— CONTENTS —

Safety instructions	2
<hr/>	
1 PRE-OPERATION INSTRUCTIONS	7
<hr/>	
1.1 Unpacking and checking the product.....	7
1.1.1 Product confirmation	7
1.1.2 SERIAL number check.....	8
1.2 Component names	9
2 INSTALLATION	10
<hr/>	
2.1 Pre-installation instructions	10
2.2 Installation procedure	10
2.3 Encoder specification / terminating resistor switch setting.....	18
2.4 Wiring.....	21
2.5 Encoder cable	26
2.6 Terminals.....	28
3 ENCODER SPECIFICATIONS	29
<hr/>	
3.1 Encoder	29
4 ENCODER FEEDBACK CONTROL	31
<hr/>	
4.1 Wiring examples (standard models)	31
4.2 Specifications (with the E800 series inverter)	32
5 VECTOR CONTROL	33
<hr/>	
5.1 Wiring examples (standard models)	33
5.2 Specifications (with the E800 series inverter)	36

APPENDIX	37
Appendix 1 Instructions for compliance with the EU Directives	37
Appendix 2 Instructions for EAC	38
Appendix 3 Restricted Use of Hazardous Substances in Electronic and Electrical Products	39
Appendix 4 Referenced Standard (Requirement of Chinese standardized law)	40
REVISIONS	43









1 PRE-OPERATION INSTRUCTIONS

1.1 Unpacking and checking the product

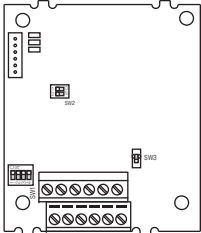
Take the plug-in option out of the package, check the product name, and confirm that the product is as you ordered and intact. This product is a plug-in option made for the FR-E800 series inverters.

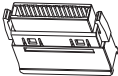
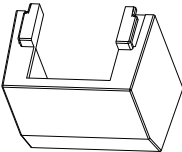
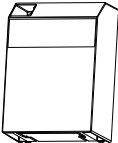
1.1.1 Product confirmation

Check the enclosed items.

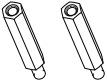
<p>Plug-in option: 1</p> 	<p>Mounting screw (M3 × 8 mm): 2 (Refer to page 12, page 14.)</p> 	<p>Junction connector: 1 (Refer to page 11, page 13.)</p> 	<p>Option small cover: 1 (Refer to page 14.)</p> 	<p>Front cover for plug-in option: 1 (Refer to page 12, page 14.)</p> 
<p>Recessed neck screw (M3 × 7): 1 (Refer to page 12, page 15.)</p> 	<p>Straight spacer: 1 (Refer to page 11, page 13.)</p> 	<p>L-shaped spacer: 1 (Refer to page 11, page 13.)</p> 	<p>Hexagon spacer: 2 (Refer to page 11, page 13.)</p> 	

NOTE

- Connection diagrams in this Instruction Manual appear with the control logic of the input terminals as sink logic, unless otherwise specified. (For the control logic, refer to the FR-E800 Instruction Manual (Connection).)

1.1.2 SERIAL number check

The FR-A8AP can be used for the inverter models listed below with the following SERIAL number or later. Check the SERIAL number indicated on the inverter rating plate or package. For the location of the rating plate, refer to the FR-E800 Instruction Manual (Connection).

Rating plate

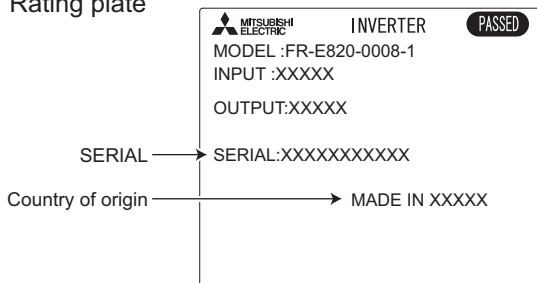

Rating plate example

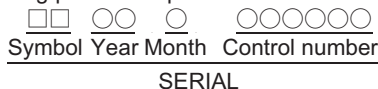



The SERIAL consists of two symbols, three characters indicating the production year and month, and six characters indicating the control number.
The last two digits of the production year are indicated as the Year, and the Month is indicated by 1 to 9, X (October), Y (November), or Z (December).

- FR-E800 series

Model	Country of origin indication	SERIAL number
FR-E820-0008(0.1K) to 0330(7.5K) FR-E840-0016(0.4K) to 0170(7.5K) FR-E860-0017(0.75K) to 0120(7.5K) FR-E820S-0008(0.1K) to 0110(2.2K)	MADE in Japan	□□208○○○○○ or later

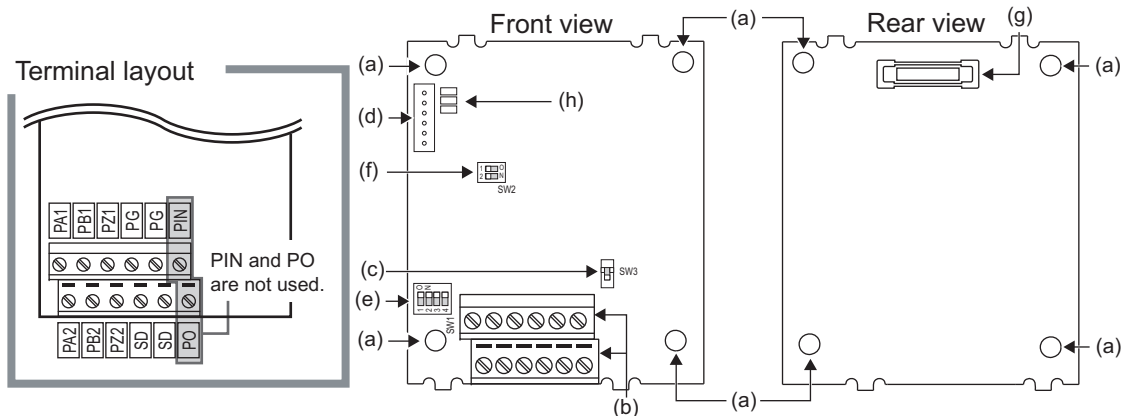
1.2 Component names



Symbol	Name	Description	Refer to page
a	Mounting hole	Used to fix this product to the inverter by inserting a mounting screw or a spacer.	16
b	Terminal block	Connected with the encoder.	21
c	Encoder type selection switch (SW3)	Switches the encoder type (differential line driver/complementary).	18
d	CON2 connector	Not used.	—
e	Terminating resistor selection switches (SW1)	Switches ON or OFF the internal terminating resistor.	18
f	Switches (SW2) for manufacturer setting	Do not change the initially-set status. (Switches 1 and 2 are OFF )	—
g	Board mounted option connector	Connects to the option connector of the inverter.	10
h	LED for manufacturer check	Not used.	—

2 INSTALLATION

2.1 Pre-installation instructions

Check that the inverter's input power and the control circuit power are both OFF.

CAUTION

- Do not install or remove this product while the inverter power is ON. Doing so may damage the inverter or this product.
 - To avoid damage due to static electricity, static electricity in your body must be discharged before you touch the product.
-

2.2 Installation procedure

◆ Installing the option

The FR-E800 series inverter has only one plug-in option connector.

NOTE

- When installing the plug-in option, prevent cables being caught between parts. Otherwise the inverter and the option may be damaged.
-

■ For the FR-E820-0175(3.7K) or lower, FR-E840-0170(7.5K) or lower, and FR-E860-0120(7.5K) or lower

1. Remove the inverter front cover. (Refer to the FR-E800 Instruction Manual (Connection) for instructions to remove the cover.)
2. Use a nipper or the like to cut off the bottom of the front cover for plug-in option.

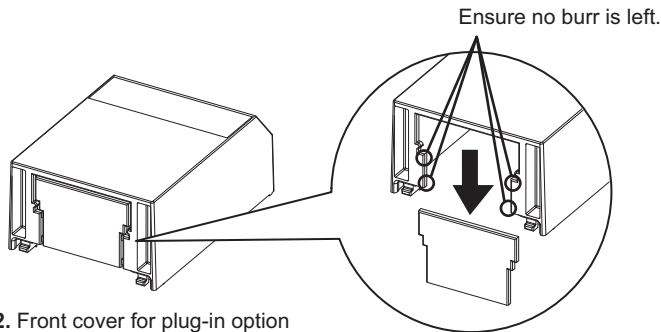

2. Front cover for plug-in option
3. Fit the L-shaped spacer, straight spacer, and junction connector to the plug-in option as shown in the figure on the [page 12](#). Fit the junction connector to the guide of the connector of the plug-in option, and insert the junction connector as far as it goes. Fit the L-shaped spacer to the plug-in option so that the lower edge of the option placed on the ridge of the spacer.

4. Remove the body screws of the inverter, then install the hexagon spacers to the inverter (tightening torque 0.56 to 0.75 N·m).
5. Fit the junction connector, which has been connected to the plug-in option, to the guide of the option connector on the inverter, and insert the junction connector as far as it goes.
6. Fasten this product to the inverter using the two mounting screws through the holes on either side (tightening torque 0.33 to 0.40 N·m). If the connector is not inserted deep enough, the screws cannot be tightened properly. Check the connector.
7. Connect cables to the terminal block of the plug-in option. (Refer to [page 21](#) for the wiring.)
8. After wiring of the plug-in option has been completed, mount the front cover for the plug-in option to the inverter.

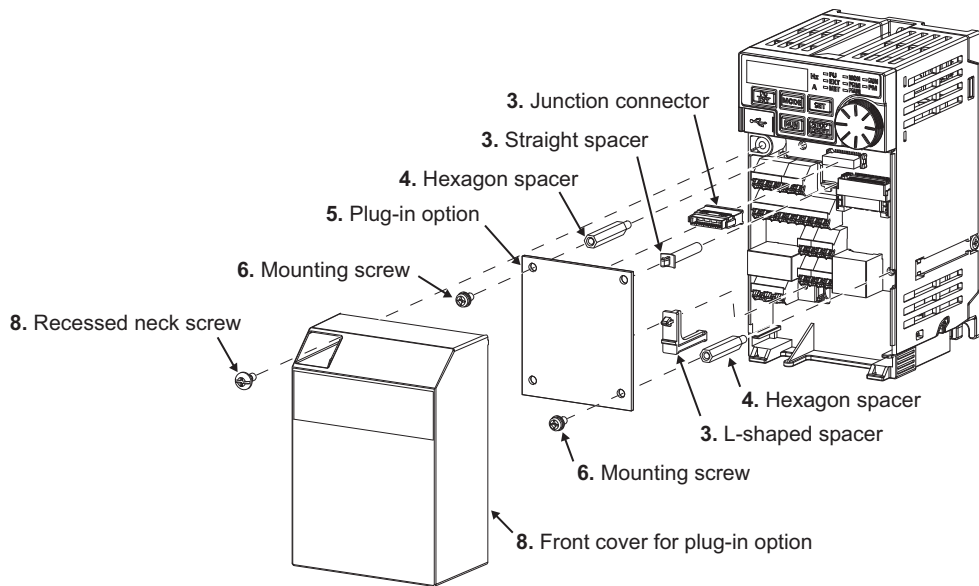

■ For the FR-E820-0240(5.5K) or higher

1. Remove the upper front cover and the lower front cover from the inverter. (Refer to the FR-E800 Instruction Manual (Connection) for instructions to remove the covers.)
2. Use a nipper or the like to cut off the dummy cover of the lower front cover in order to install the option small cover.

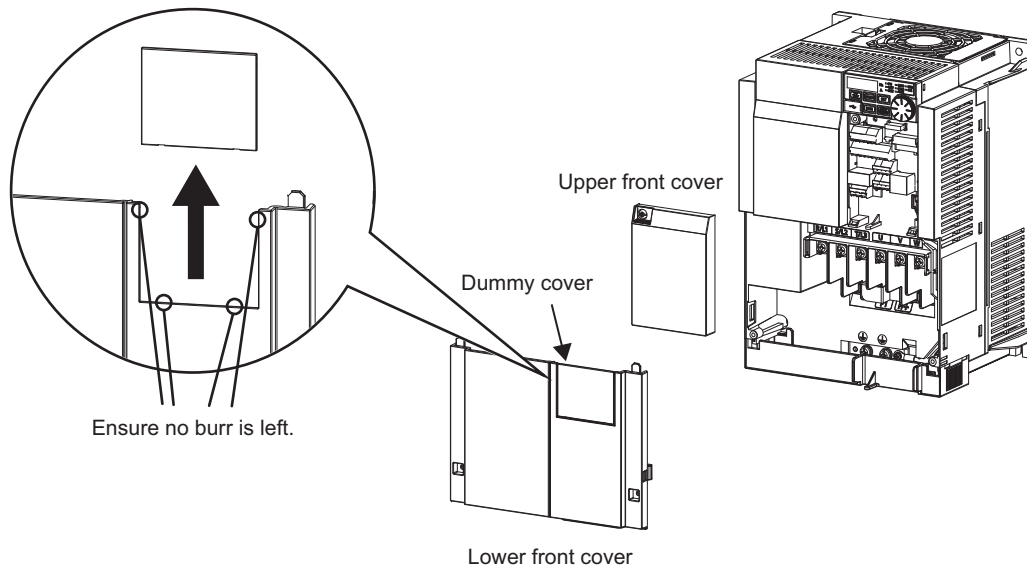

3. Use a nipper or the like to cut off the bottom of the front cover for plug-in option. (For details, refer to [page 11](#).)
4. Fit the L-shaped spacer, straight spacer, and junction connector to the plug-in option as shown in the figure on the [page 15](#). Fit the junction connector to the guide of the connector of the plug-in option, and insert the junction connector as far as it goes. Fit the L-shaped spacer to the plug-in option so that the lower edge of the option placed on the ridge of the spacer.

5. Remove the body screws of the inverter, then install the hexagon spacers to the inverter (tightening torque 0.56 to 0.75 N·m).
6. Fit the junction connector, which has been connected to the plug-in option, to the guide of the option connector on the inverter, and insert the junction connector as far as it goes.
7. Fasten this product to the inverter using the two mounting screws through the holes on either side (tightening torque 0.33 to 0.40 N·m). If the connector is not inserted deep enough, the screws cannot be tightened properly. Check the connector.
8. Connect cables to the terminal block of the plug-in option. (Refer to [page 21](#) for the wiring.)
9. After wiring of the plug-in option has been completed, mount the front cover for the plug-in option to the inverter.
10. Install the option small cover to the front cover for plug-in option by inserting the small cover into the front cover and slide it toward the rear of the inverter.

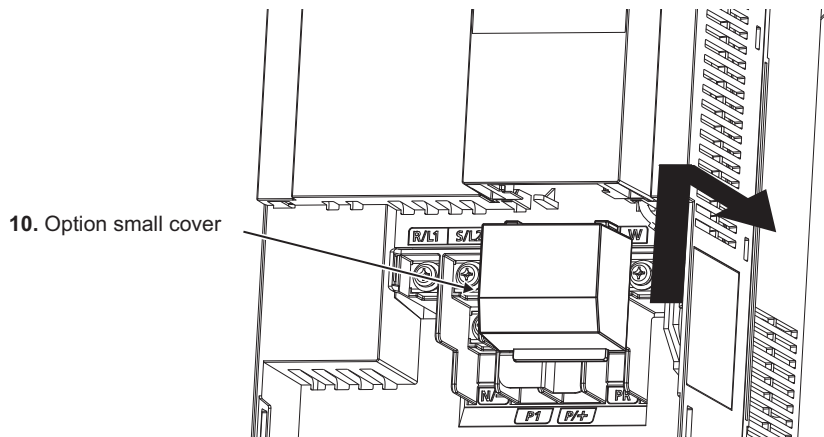

11. Install the lower front cover to the inverter.

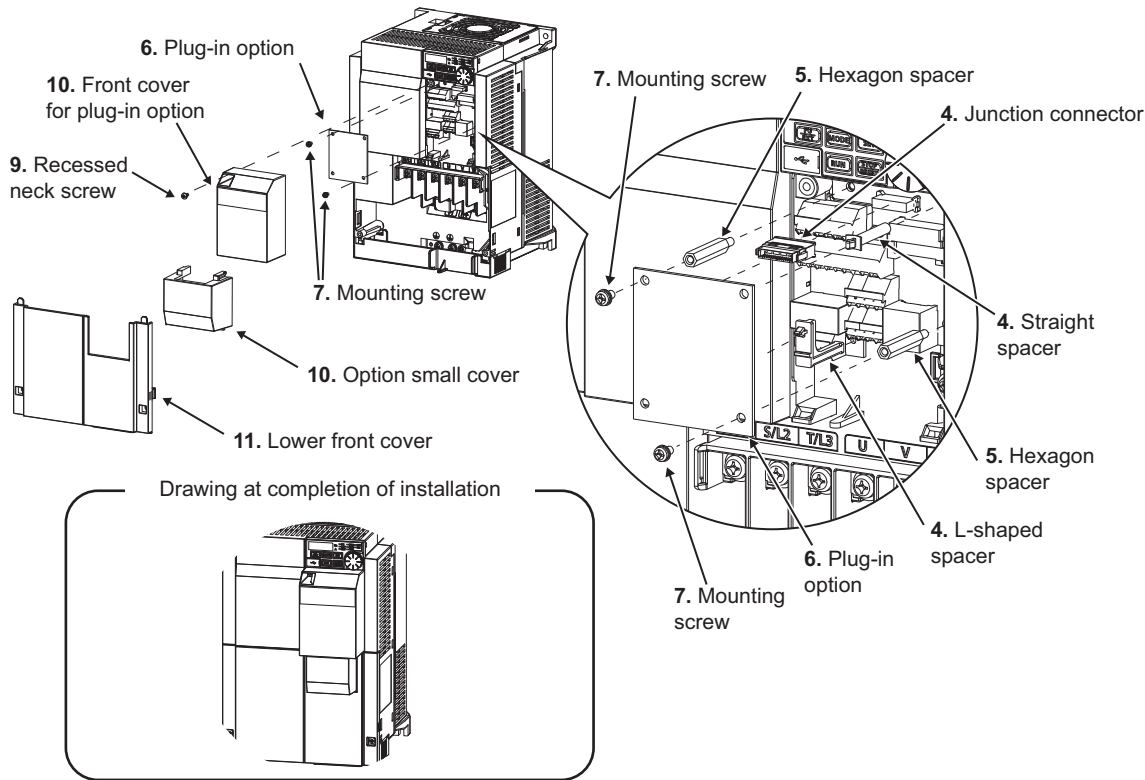

◆ Insertion positions for screws and spacers

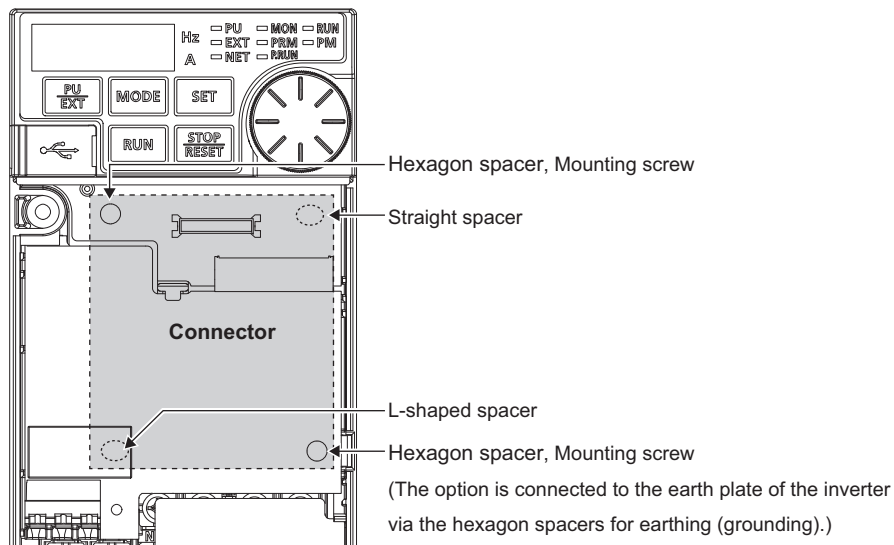

Insertion positions for screws and spacers

NOTE

- When the junction connector is installed to the plug-in option, the option is fixed with the hooks of the connector. The junction connector cannot be removed from the plug-in option.
- When removing the front cover for plug-in option from the inverter, note that the recessed neck screw cannot be removed from the front cover for plug-in option.
- When installing/removing the plug-in option, hold the sides of the option. Do not press on the parts on the option circuit board. Stress applied to the parts by pressing, etc. may cause a failure.
- Be careful not to drop mounting screws during the installation or removal of the plug-in option.
- When the inverter cannot recognize the option due to improper installation or any other reason, the protective function (E.1) is activated and the inverter cannot be operated.

Mounted position	Fault indication
Option connector	E. 1

- When removing the plug-in option, remove the two screws on either side, and then pull it straight out. Pressure applied to the option connector and to the option board may break the option.

2.3 Encoder specification / terminating resistor switch setting

◆ Encoder specification selection switch (SW3)

Select either differential line driver or complementary.

It is initially set to the differential line driver. Switch its position according to the output circuit.

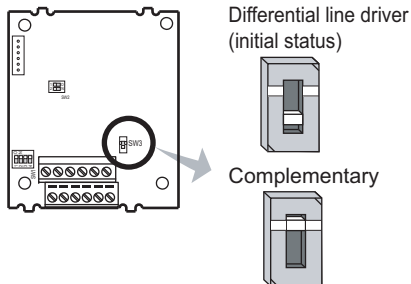

◆ Terminating resistor selection switch (SW1)

Select "ON"/"OFF" of the internal terminating resistor. Set the switch to "ON" (initial status) when an encoder output type is differential line driver and set to "OFF" when complementary.

ON: with internal terminating resistor (initial setting status)

OFF: without internal terminating resistor

Internal terminating
resistor-ON
(initial status)

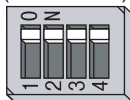

Internal terminating
resistor-OFF

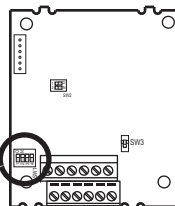
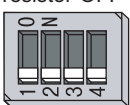

NOTE

- Set all switches to the same setting ("ON"/"OFF").
- If the encoder output type is differential line driver, set the terminating resistor switch to the "OFF" position when sharing the same encoder with other unit (CNC (computerized numerical controller), etc) or a terminating resistor is connected to other unit.

◆ Motor and switch setting

Motor		Encoder specification selection switch (SW3)	Terminating resistor selection switch (SW1)	Power specifications ^{*2}
Mitsubishi Electric high-performance energy-saving motor with encoder	SF-PR-SC	Complementary	OFF	12V to 24V
Mitsubishi Electric Vector control dedicated motor	SF-V5RU	Complementary	OFF	12V
Mitsubishi Electric inverter-driven geared motor for encoder feedback control	GM-DZ GM-DP	Differential	ON	5V
Mitsubishi standard motor with encoder Mitsubishi high-efficiency motor with encoder	SF-JR	Differential	ON	5V
	SF-HR	Differential	ON	5V
	Other	*1	*1	*1*3
Mitsubishi Electric constant-torque motor with encoder	SF-JRCA	Differential	ON	5V
	SF-HRCA	Differential	ON	5V
	Other	*1	*1	*1*3
Other manufacturer's motor with encoder		*1	*1	*1*3

*1 Set according to the motor (encoder).

*2 Prepare the power supply (5 V/12 V/15 V/24 V) for the encoder according to the encoder's output voltage.

*3 When the encoder output is the differential line driver type, only 5 V can be input.

NOTE

- The SW2 switches are for manufacturer setting. Do not change the setting.
- When the power supply of the inverter is turned OFF, also turn off the power supply of the encoder. Otherwise, the plug-in option may be damaged.

2.4 Wiring

1. Use twisted pair shield cables (0.2 mm² or larger) to connect the FR-A8AP and position detector. For the wiring to the terminals PG and SD, use several cables in parallel or use a thick cable, according to the wiring length. To protect the cables from noise, run them away from any source of noise (e.g. the main circuit and power voltage).

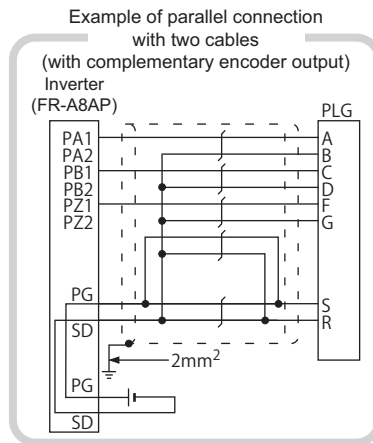

Wiring length	Parallel connection (Cable gauge 0.2 mm ²)	Larger-size cable
Within 10 m	At least two cables in parallel	0.4mm ² or larger
Within 20 m	At least four cables in parallel	0.75mm ² or larger
Within 100 m ^{*1}	At least six cables in parallel	1.25mm ² or larger

*1 When differential driver is set and a wiring length is 30 m or more

The wiring length can be extended to 100 m by slightly increasing the 5 V power supply (approx. 5.5 V) and using six or more cables with gauge size of 0.2 mm² in parallel or a cable with gauge size of 1.25 mm² or more. Note that the voltage applied should be within power supply specifications of encoder.

- To reduce noise of the encoder cable, earth (ground) the encoder shielded cable to the enclosure (as close as the inverter) with a P clip or U clip made of metal.

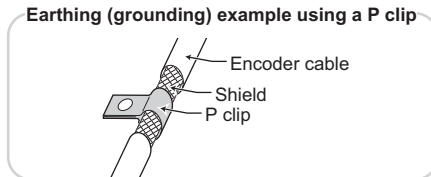

NOTE

- For details of the optional encoder dedicated cable (FR-JCBL/FR-V7CBL), refer to [page 26](#).
- FR-V7CBL is provided with a P clip for earthing (grounding) shielded cable.

2. Wire the shielded twisted pair cable after stripping its sheath to make its cables loose. Also, protect the shielded cable of the shielded twisted pair cable to ensure that it will not make contact with the conductive area.

(perform protective treatment)

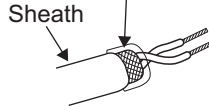

Shielded twisted pair cable

Strip off the sheath as shown below. If too much of the wires is stripped, a short circuit may occur with neighboring wires. If not enough of the wire is stripped, wires may become loose and fall out. Twist the stripped end of wires to prevent them from fraying. Do not solder it.
Cable sheath stripping length

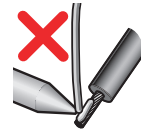
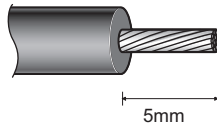

Crimp the blade terminal.

Insert wires to a blade terminal, and check that the wires come out for about 0 to 0.5 mm. Check the condition of the blade terminal after crimping. Do not use a blade terminal of which the crimping is inappropriate, or the face is damaged.

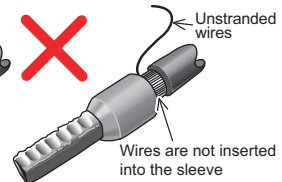
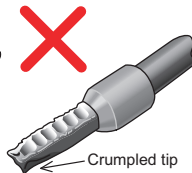
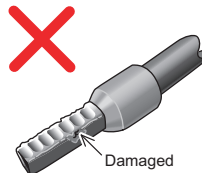
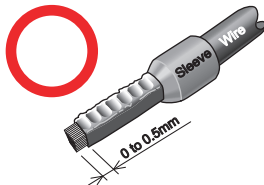

NOTE

- Information on crimp terminals

Commercially available products (as of December 2019)

Phoenix Contact Co., Ltd.

Screw Size	Cable gauge (mm ²)	Ferrule terminal model		Manufacturer
		With insulation sleeve	Without insulation sleeve	
M2	0.3	AI 0,34-6TQ	A 0,34-7	CRIMPFOX 6
	0.5	AI 0,5-6WH	A 0,5-6	

NICHIFU Co., Ltd.

Screw Size	Cable gauge (mm ²)	Blade terminal product number	Insulation product number	Crimping tool product number
M2	0.3~0.75	BT 0.75-7	VC 0.75	NH 69

- When using a blade terminal (without insulation sleeve), take caution that the twisted wires do not come out.

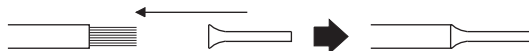

3. Loosen the terminal screw and insert the cable into the terminal.

Screw Size	Tightening Torque	Cable Size	Screwdriver
M2	0.22N · m to 0.25N · m	0.3mm ² to 0.75mm ²	Small ⊖ flat-blade screwdriver (Tip thickness: 0.4 mm/tip width: 2.5 mm)

NOTE

- Undertightening can cause cable disconnection or malfunction. Overtightening can cause a short circuit or malfunction due to damage to the screw or unit.
- When one position detector is shared between FR-A8AP and CNC (computerized numerical controller), its output signal should be connected as shown below. In this case, the wiring length between FR-A8AP and CNC should be as short as possible, within 5 m.

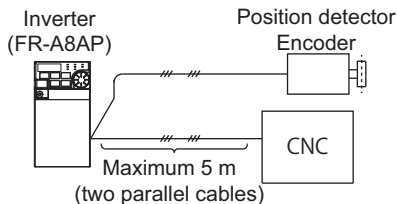

CAUTION

- Do not use empty terminals as junction terminals because they are used in the option unit. If they are used as the junction terminals, the option unit may be damaged.
- After wiring, wire offcuts must not be left in the inverter. They may cause a fault, failure or malfunction.

2.5 Encoder cable

◆ SF-PR-SC/SF-V5RU with encoder

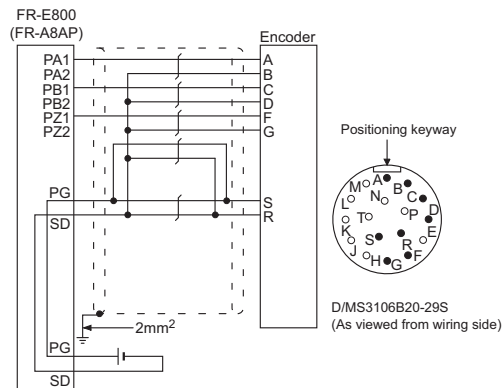
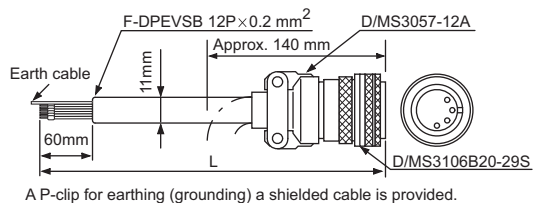

Type	Length L (m)
FR-V7CBL5	5
FR-V7CBL15	15
FR-V7CBL30	30

◆ GM-DZ/GM-DP/SF-JR/SF-HR/SF-JRCA/SF-HRCA with encoder

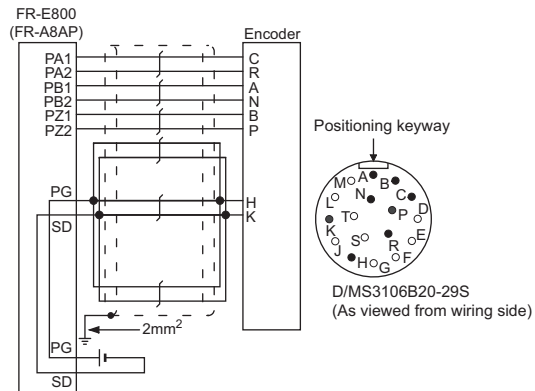
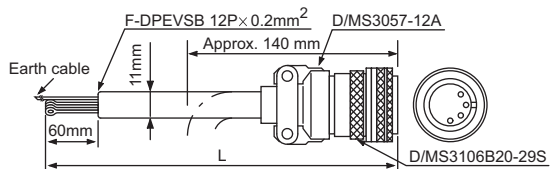

Type	Length L (m)
FR-JCBL5	5
FR-JCBL15	15
FR-JCBL30	30

◆ Connection terminal compatibility table

Motor		SF-PR-SC, SF-V5RU	GM-DZ, GM-DP, SF-JR, SF-HR, SF-JRCA, SF-HRCA (with Encoder)
Encoder cable		FR-V7CBL	FR-JCBL
FR-A8AP terminal	PA1	PA	PA
	PA2	Keep this open.	PAR
	PB1	PB	PB
	PB2	Keep this open.	PBR
	PZ1	PZ	PZ
	PZ2	Keep this open.	PZR
	PG	PG	5E
	SD	SD	AG2

2.6 Terminals

Terminal Symbol	Terminal Name	Description		
PA1	Encoder A-phase signal input terminal	A-phase signal is input from the encoder.	For details of pulse signal, refer to page 29 .	
PA2	Encoder A-phase inverse signal input terminal			
PB1	Encoder B-phase signal input terminal	B-phase signal is input from the encoder.		
PB2	Encoder B-phase inverse signal input terminal			
PZ1	Encoder Z-phase signal input terminal	Z-phase signal is input from the encoder. (Not used for the encoder feedback control.)		
PZ2	Encoder Z-phase inverse signal input terminal			
PG	Encoder power supply (positive side) input terminal	Input power for the encoder power supply. Connect the external power supply (5 V, 12 V, 15 V, 24 V) and the encoder power cable. When the encoder output is the differential line driver type, only 5 V can be input. Make sure the voltage of the external power supply the same as the encoder output voltage. (Check the encoder specification.)		
SD	Encoder power supply ground terminal			

3 ENCODER SPECIFICATIONS

3.1 Encoder

◆ Position detection (pulse encoder)

Output pulse specifications

Differential line driver

A/ \bar{A} signal 1000 P/R to 4096 P/R

B/ \bar{B} signal 1000 P/R to 4096 P/R

Z/ \bar{Z} signal 1 P/R

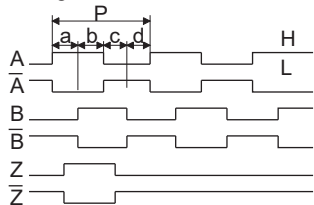

Complementary

A signal 1000 P/R to 4096 P/R

B signal 1000 P/R to 4096 P/R

Z signal 1 P/R

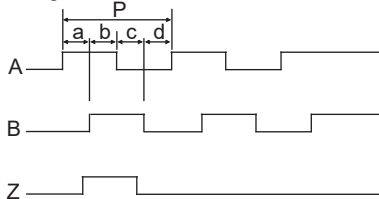

Position detector
Encoder



· When rotation is counterclockwise as viewed from the shaft end (A) of the encoder.

· a, b, c, d should be $(1/4 \pm 1/8)P$

NOTE

- When encoder feedback control, vector control are used together, the encoder is shared between these controls. Use an encoder which has a pulse count of 1000 to 4096 ppr (pulse per revolution).
- The encoder should be coupled with the motor shaft or the spindle oriented with a speed ratio of 1 to 1 without any mechanical looseness.
- To ensure correct operation, the encoder must be set in the proper rotation direction and the A and B phases connected correctly.

◆ Power supply

Choose a power supply for encoder according to the encoder used (5 V/12 V/15 V/24 V). When the encoder output is the differential line driver type, only 5 V can be input. Make sure the voltage of the external power supply the same as the encoder output voltage. (Check the encoder specification.)

When an encoder is used under encoder feedback control, and vector control, the power supply is shared between the inverter and encoder.

- Specifications of the encoders equipped in the motors with encoders and the vector-control dedicated motors

Item	Encoder for SF-PR-SC and SF-V5RU	Encoder for GM-DZ, GM-DP, SF-JR, SF-HR, SF-JRCA and SF-HRCA
Resolution	2048 Pulse/rev	1024 Pulse/rev
Power supply voltage	12 VDC $\pm 10\%$, 24 VDC $\pm 10\%$	5 VDC $\pm 10\%$
Current consumption	150 mA	150 mA
Output signal form	Phase A and Phase B: 90 degrees out of phase, Phase Z: 1 pulse/rev	Phase A and Phase B: 90 degrees out of phase, Phase Z: 1 pulse/rev
Output circuit	Complementary	Differential line driver AM26LS31 equivalent
Output voltage	H level: (Power supply for encoder - 3 V) or more, L level: 3 V or less	H level: 2.4 V or more, L level: 0.5 V or less

NOTE

- When the input power supply voltage to the encoder and its output voltage differ, the protective function (E.ECT) may be activated.

◆ PARAMETER SETTINGS

For the parameters for encoder, refer to the FR-E800 Instruction Manual (Function).

4 ENCODER FEEDBACK CONTROL

Mount FR-A8AP to an FR-E800 series inverter to perform encoder feedback control under V/F control or Advanced magnetic flux vector control.

This controls the inverter output frequency so that the motor speed is constant to the load variation by detecting the motor speed with the speed detector (encoder) to feed back to the inverter.

For the details of the parameters used for encoder feedback control, refer to the FR-E800 Instruction Manual (Function).

4.1 Wiring examples (standard models)

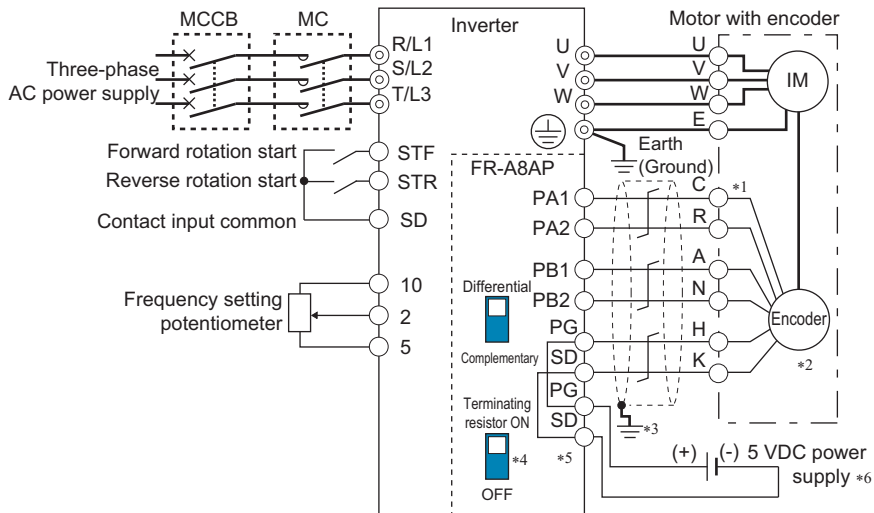

- *1 The pin number differs according to the encoder used.
- *2 Connect the encoder so that there is no looseness between the motor and motor shaft. Speed ratio should be 1:1.
- *3 Earth (Ground) the shielded cable of the encoder cable to the enclosure with a P clip, etc. (Refer to [page 22](#).)
- *4 For the differential line driver, set the terminating resistor selection switch to on position (initial status) to use. (Refer to [page 19](#)) Note that the terminating resistor switch should be set to off position when sharing the same encoder with other unit (CNC, etc) and a terminating resistor is connected to other unit.
For the complementary, set the switch to off position.
- *5 For terminal compatibility of the FR-JCBL, FR-V7CBL and FR-A8AP, refer to [page 28](#).
- *6 A separate power supply of 5 V/12 V/15 V/24 V is necessary according to the encoder power specification. When the encoder output is the differential line driver type, only 5 V can be input.
Make the voltage of the external power supply the same as the encoder output voltage, and connect the external power supply between PG and SD.

4.2 Specifications (with the E800 series inverter)

Item	Description
Speed variation ratio	±0.1% (100% means 3600 r/min)
Function	<ul style="list-style-type: none"> • Setting of speed feedback range • Setting of feedback gain • Setting of encoder rotation direction
Maximum speed	V/F control: 590 Hz, Advanced magnetic flux vector control: 400 Hz (102400 pulse/s or less encoder pulses)

5 VECTOR CONTROL

When FR-A8AP is mounted on the FR-E800 series, full-scale vector control operation can be performed using a motor with encoder. Speed control and torque control by vector control can be performed. (Refer to the FR-E800 Instruction Manual (Function) for details.)

5.1 Wiring examples (standard models)

◆ Speed control

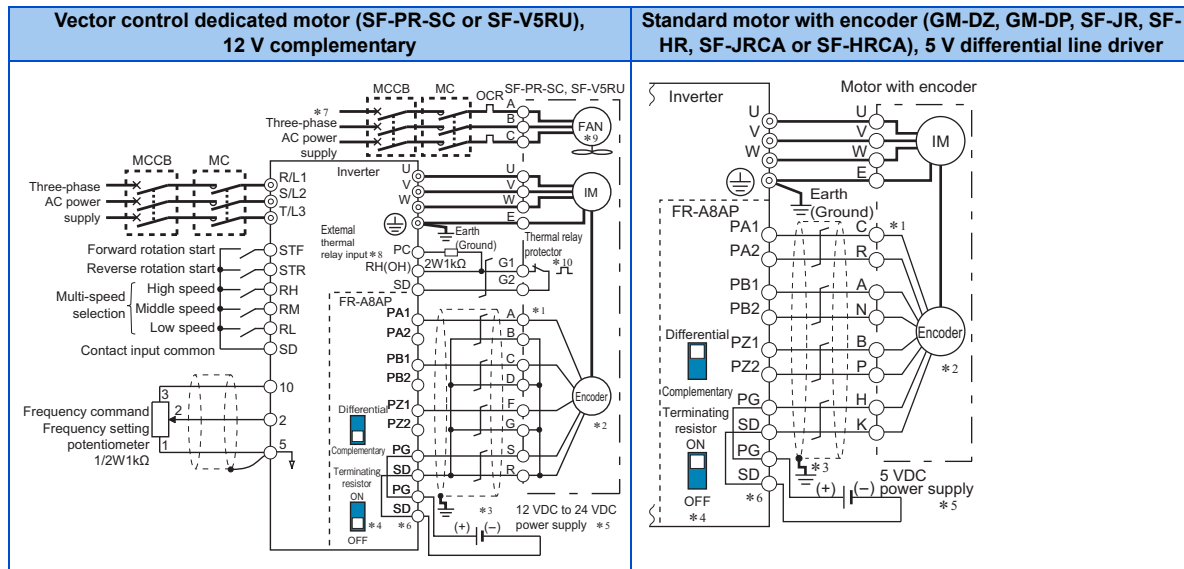

◆ Torque control

**Vector control dedicated motor (SF-PR-SC or SF-V5RU),
12 V complementary**

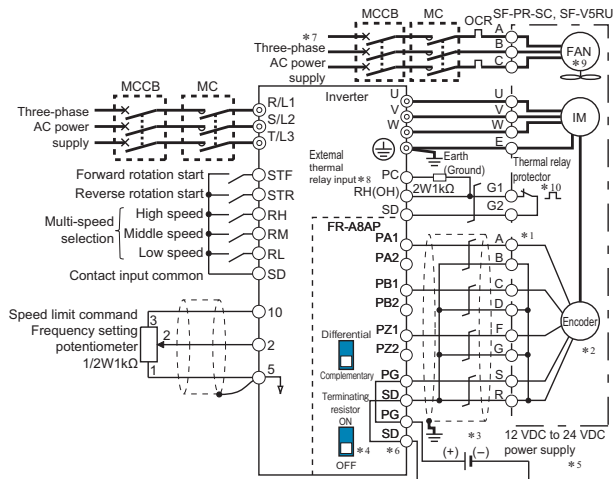

**Standard motor with encoder (GM-DZ, GM-DP, SF-JR,
SF-HR, SF-JRCA or SF-HRCA), 5 V differential line driver**

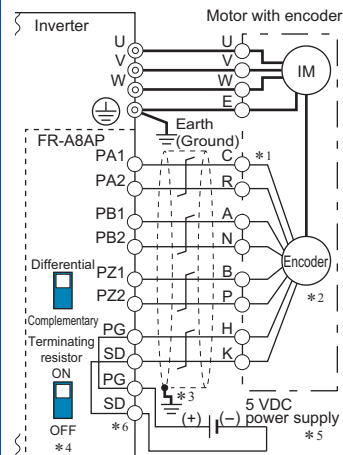

- *1 The pin number differs according to the encoder used.
Speed, control and torque control by pulse train input are available with or without the Z-phase being connected.
- *2 Connect the encoder so that there is no looseness between the motor and motor shaft. Speed ratio must be 1:1.
- *3 Earth (ground) the shield of the encoder cable to the enclosure using a tool such as a P-clip. (Refer to [page 22.](#))
- *4 For the complementary, set the terminating resistor selection switch to OFF position. (Refer to [page 19.](#))
- *5 A separate power supply of 5 V/12 V/15 V/24 V is necessary according to the encoder power specification.
When the encoder output is the differential line driver type, only 5 V can be input.
Make the voltage of the external power supply the same as the encoder output voltage, and connect the external power supply across PG and SD.
- *6 For terminal compatibility of the FR-JCBL, FR-V7CBL, and FR-A8AP, refer to [page 28.](#)
- *7 A single-phase power supply (200 V/50 Hz, 200 to 230 V/60 Hz) is used for the fan for the dedicated motor (SF-V5RU).
- *8 Connect the recommended 2 W 1 kΩ resistor between terminals PC and OH. (Recommended product: MOS2C102J 2W1kΩ by KOA Corporation) Insert the input line and the resistor to a 2-wire blade terminal, and connect the blade terminal to terminal OH. (For the recommended 2-wire blade terminals, refer to [page 24.](#))
Remove jumpers connecting terminals PC and S1 and terminals PC and S2, and perform wiring as follows. Insulate the lead wire of the resistor, for example by applying a contraction tube, and shape the wires so that the resistor and its lead wire do not touch other cables. Caulk the lead wire securely together with the thermal protector input line using a 2-wire blade terminal. (Do not subject the lead wire's bottom area to an excessive pressure.)
The thermal protector can be connected to the standard model and the Ethernet model only.
To use a terminal as terminal OH, assign the OH (External thermal relay input) signal to an input terminal. (Set "7" in any of **Pr.178** to **Pr.184**. For details, refer to the FR-E800 Instruction Manual (Function).)

When OH signal is assigned to terminal RH (**Pr.182** = "7")

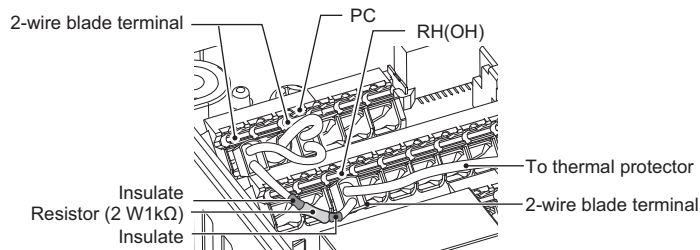

- *9 The SF-PR-SC does not have a cooling fan.
- *10 Some SF-PR-SC models have a thermal protector.

5.2 Specifications (with the E800 series inverter)

Item		Description
Speed control	Speed control range	1:1500 (both driving/regeneration ^{*1})
	Speed variation ratio	±0.01% (100% means 3000 r/min)
	Speed response	30 Hz
	Maximum speed	400 Hz (102400 pulse/s or less encoder pulses)
Torque control	Torque control range	1:50
	Absolute torque accuracy	±10% ^{*2}
	Repeated torque accuracy	±5% ^{*2}
Function		<ul style="list-style-type: none">• Setting of speed feedback range• Setting of feedback gain• Setting of encoder rotation direction

*1 Regeneration unit (option) is necessary for regeneration

*2 For the dedicated motor under rated load

APPENDIX

Appendix 1 Instructions for compliance with the EU Directives

The EU Directives are issued to standardize different national regulations of the EU Member States and to facilitate free movement of the equipment, whose safety is ensured, in the EU territory.

Since 1996, compliance with the EMC Directive that is one of the EU Directives has been legally required. Since 1997, compliance with the Low Voltage Directive, another EU Directive, has been also legally required. When a manufacturer confirms its equipment to be compliant with the EMC Directive and the Low Voltage Directive, the manufacturer must declare the conformity and affix the CE marking.

- The authorized representative in the EU

The authorized representative in the EU is shown below.

Name: Mitsubishi Electric Europe B.V.

Address: Mitsubishi-Electric-Platz 1, 40882 Ratingen, Germany

◆ EMC Directive

We declare that this product conforms with the EMC Directive when installed in a compatible inverter, and affix the CE marking on the packaging plate.

- EMC Directive: 2014/30/EC
- Standard(s): EN 61800-3:2004+A1:2012 (Second environment / PDS Category "C3")

■ Note

- To install and wire the inverter, refer to the "Instructions for compliance with the EU Directives" in the Instruction Manual enclosed with the inverter.
- Confirm that the final integrated system with the inverter conforms with the EMC Directive.



Appendix 2 Instructions for EAC

The product certified in compliance with the Eurasian Conformity has the EAC marking on the packaging plate.

Note: EAC marking

In 2010, three countries (Russia, Belarus, and Kazakhstan) established a Customs Union for the purposes of revitalizing the economy by forming a large economic bloc by abolishing or reducing tariffs and unifying regulatory procedures for the handling of articles.

Products to be distributed over these three countries of the Customs Union must comply with the Customs Union Technical Regulations (CU-TR), and the EAC marking must be affixed to the products.

For information on the country of origin, manufacture year and month, and authorized sales representative (importer) in the CU area of this product, refer to the following:

- Country of origin indication

Check the package of this product.

Example: MADE IN JAPAN

- Manufactured year and month

Check the SERIAL number indicated on this product.

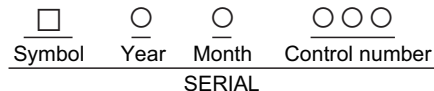

The SERIAL consists of one symbol, two characters indicating the production year and month, and three characters indicating the control number. The last digit of the production year is indicated as the Year, and the Month is indicated by 1 to 9, X (October), Y (November), or Z (December).

- Authorized sales representative (importer) in the CU area

The authorized sales representative (importer) in the CU area is shown below.

Name: Mitsubishi Electric (Russia) LLC

Address: 52, bld 1 Kosmodamianskaya Nab 115054, Moscow, Russia

Phone: +7 (495) 721-2070

Fax: +7 (495) 721-2071

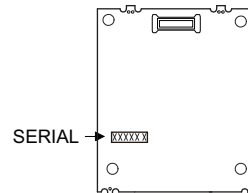

Appendix 3 Restricted Use of Hazardous Substances in Electronic and Electrical Products

The mark of restricted use of hazardous substances in electronic and electrical products is applied to the product as follows based on the "Management Methods for the Restriction of the Use of Hazardous Substances in Electrical and Electronic Products" of the People's Republic of China.

电器电子产品有害物质限制使用标识要求



本产品中所含有的有害物质的名称、含量、含有部件如下表所示。

- 产品中所含有害物质的名称及含量

部件名称 *2	有害物质 *1					
	铅 (Pb)	汞 (Hg)	镉 (Cd)	六价铬 (Cr (VI))	多溴联苯 (PBB)	多溴二苯醚 (PBDE)
电路板组件 (包括印刷电路板及其构成的零部件, 如电阻、电容、集成电路、连接器等)、电子部件	×	○	×	○	○	○
金属壳体、金属部件	×	○	○	○	○	○
树脂壳体、树脂部件	○	○	○	○	○	○
螺丝、电线	○	○	○	○	○	○

上表依据 SJ/T11364 的规定编制。

○：表示该有害物质在该部件所有均质材料中的含量均在 GB/T26572 规定的限量要求以下。

×：表示该有害物质在该部件的至少一种均质材料中的含量超出 GB/T26572 规定的限量要求。

*1 即使表中记载为 ×，根据产品型号，也可能会有有害物质的含量为限制值以下的情况。

*2 根据产品型号，一部分部件可能不包含在产品中。

Appendix 4 Referenced Standard (Requirement of Chinese standardized law)

This Product is designed and manufactured accordance with following Chinese standards.

EMC: GB/T 12668.3

MEMO

MEMO

REVISIONS

*The manual number is given on the bottom left of the back cover.

Revision date	*Manual number	Revision
Jun. 2020	IB(NA)-0600935ENG-A	First edition

INVERTER

mitsubishi
MITSUBISHI ELECTRIC CORPORATION

HEAD OFFICE: TOKYO BUILDING 2-7-3, MARUNOUCHI, CHIYODA-KU, TOKYO 100-8310, JAPAN